

Waste Management of Canada Corporation

Ottawa Transfer and Processing Facility Design & Operations Report

Prepared by:

AECOM

300 – 300 Town Centre Boulevard

Markham, ON, Canada L3R 5Z6

www.aecom.com

905 477 8400 tel

905 477 1456 fax

Project Number:

60191228-15

Date:

March, 2011

Statement of Qualifications and Limitations

The attached Report (the "Report") has been prepared by AECOM Canada Ltd. ("Consultant") for the benefit of the client ("Client") in accordance with the agreement between Consultant and Client, including the scope of work detailed therein (the "Agreement").

The information, data, recommendations and conclusions contained in the Report (collectively, the "Information"):

- is subject to the scope, schedule, and other constraints and limitations in the Agreement and the qualifications contained in the Report (the "Limitations")
- represents Consultant's professional judgement in light of the Limitations and industry standards for the preparation of similar reports
- may be based on information provided to Consultant which has not been independently verified
- has not been updated since the date of issuance of the Report and its accuracy is limited to the time period and circumstances in which it was collected, processed, made or issued
- must be read as a whole and sections thereof should not be read out of such context
- was prepared for the specific purposes described in the Report and the Agreement
- in the case of subsurface, environmental or geotechnical conditions, may be based on limited testing and on the assumption that such conditions are uniform and not variable either geographically or over time

Consultant shall be entitled to rely upon the accuracy and completeness of information that was provided to it and has no obligation to update such information. Consultant accepts no responsibility for any events or circumstances that may have occurred since the date on which the Report was prepared and, in the case of subsurface, environmental or geotechnical conditions, is not responsible for any variability in such conditions, geographically or over time.

Consultant agrees that the Report represents its professional judgement as described above and that the Information has been prepared for the specific purpose and use described in the Report and the Agreement, but Consultant makes no other representations, or any guarantees or warranties whatsoever, whether express or implied, with respect to the Report, the Information or any part thereof.

The Report is to be treated as confidential and may not be used or relied upon by third parties, except:

- as agreed in writing by Consultant and Client
- as required by-law
- for use by governmental reviewing agencies

Consultant accepts no responsibility, and denies any liability whatsoever, to parties other than Client who may obtain access to the Report or the Information for any injury, loss or damage suffered by such parties arising from their use of, reliance upon, or decisions or actions based on the Report or any of the Information ("improper use of the Report"), except to the extent those parties have obtained the prior written consent of Consultant to use and rely upon the Report and the Information. Any damages arising from improper use of the Report or parts thereof shall be borne by the party making such use.

This Statement of Qualifications and Limitations is attached to and forms part of the Report and any use of the Report is subject to the terms hereof.

March 28, 2011

Mr. Michael Clement
District Manager – Ottawa & Gatineau Districts
Waste Management
254 Westbrook Road
Ottawa, ON K0A 1L0

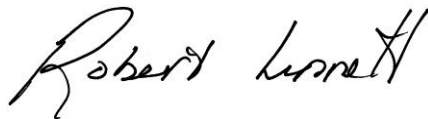
Dear Mr. Clement:

Project No: 60191228-15
**Regarding: Ottawa Transfer and Processing Facility
Design & Operations Report**

Please find enclosed the Design and Operation Report for the proposed Ottawa IC&I and C&D waste transfer and processing facility for your submission to the Ministry.

The Application, complete with attachments, has been forwarded under separate cover.

Sincerely,
AECOM Canada Ltd.



Robert W. Lippett, P.Eng.
Senior Waste Services Engineer

RWL:mm
Encl.

Table of Contents

Statement of Qualifications and Limitations Letter of Transmittal

	page
1. Introduction.....	1
2. Facility Design/Operations	2
2.1 Site Location and Land Use	2
2.2 Design Overview.....	3
2.2.1 IC&I Waste Transfer & Processing Facility.....	3
2.2.2 C & D Waste Transfer and Processing Facility	4
2.3 Description of On-Site Operations.....	5
2.3.1 Waste Accepted at the Site	5
2.3.2 Hours of Operation	5
2.3.3 IC&I Waste Transfer Station.....	5
2.3.4 C&D Waste Processing & Transfer Facility.....	6
2.3.5 Other Existing Facilities On-Site.....	6
2.3.6 Scale House	6
2.4 Vehicle Traffic.....	7
2.5 Material Balance	9
2.6 On-Site Material Storage	9
2.7 Site Storage	10
2.8 Fencing and Security.....	11
2.9 Facility Equipment and Maintenance.....	11
2.10 Staff Training	11
2.11 Waste Screening Procedure.....	12
2.12 Environmental/Emergency Measures.....	12
2.12.1 Stormwater Management	12
2.12.2 Air Discharge/Dust Control	12
2.12.3 Spills	13
2.12.4 Fire.....	13
2.13 Site Inspections and Nuisance Conditions	13
2.13.1 Odour Prevention and Control.....	13
2.13.2 Litter Prevention and Control.....	13
2.13.3 Vermin Control.....	14
2.14 Complaint Procedure	14
2.15 Record Keeping.....	14
2.16 Waste Receiving Sites.....	14
2.17 Disruption of Shipment	15
2.18 Decommissioning Plan	15
2.19 Financial Assurance	15

List of Tables

Table 1. Local Receptors within a 500 m Radius..... 3

Table 2. Summary of In/Outbound Vehicle Counts Per Hour & Per Day (at 20% recovery for reuse/recycling) 8

Table 3. Summary of In/Outbound Vehicle Counts Per Hour & Per Day (at 60% recovery for reuse/recycling) 8

Table 4. Range of In/Outbound Vehicle Counts Per Hour & Per Day (between 20 and 60% recovery for reuse/recycling) 8

Table 5. On-Site Storage..... 9

Table 6. Summary of the Maximum Amount of Various Waste Streams Present or Stored on Site 10

Appendices

Appendix A. Figures

- Figure 1. Site Location Plan, Regional Setting
- Figure 2. Site Location Plan, Local Setting
- Figure 3. Land Use Zoning & Local Receptors
- Figure 4. Site Layout
- Figure 5. Facility Layout
- Figure 6. Process Schematic

Appendix B. Drainage Study

Appendix C. Summary of Vehicle Counts & Materials Diverted/Disposed

Appendix D. Calculations of On-Site Storage

Appendix E. Site/Building Photographs

1. Introduction

Waste Management of Canada Corporation (WMCC) is seeking an amendment to their Provisional Certificate of Approval (number A461002) for their landfill site located at 2301 Carp Road, Lots 3 & 4 Concession III in Ottawa. The amendment, combined with local municipal approvals will enable WMCC to proceed with the design, construction and operation of an Industrial/Commercial and Institutional (IC&I) as well as a Construction and Demolition (C&D) Waste Transfer and Processing Facility to be located in the southwest corner of the landfill site property adjacent to William Mooney Road.

WMCC is currently transferring locally generated (WMCC customers) IC&I as well as C&D waste materials utilizing a competitor's transfer station located in the vicinity of their landfill site (Tomlinson's Environmental Services' transfer station located approximately 1 km north/northwest of WMCC's landfill site). This tonnage is in the order of 100 tonnes/day (split 85 tonnes and 15 tonnes/day of IC&I and C&D waste materials) For the reasons noted below WMCC wants to bring the transfer operations in house and accordingly has initiated a design and approvals process for the proposed transfer and processing facility to process up to 400 tonnes/day or 124,800 tonnes/year of IC&I and C&D waste materials. The Design and Operations report that follows is a key component of this design and approvals process.

This transfer station is required for the following reasons:

- a) As a means to manage WMs existing local area customer requirements independently of their competitor's infrastructure;
- b) As a means to manage growth while their landfill expansion project is proceeding through the permitting process;
- c) WMCC wants to significantly increase the diversion of waste materials (recycling), in particular C&D waste materials. This facility will serve as their local platform to achieve that end; and
- d) The proposed IC&I and C&D waste Transfer & Processing Facility is not an interim facility pending the completion and approval of the Environmental Assessment of a new landfill footprint for the Ottawa Waste Management Facility (referred to as the proposed West Carlton Environmental Centre - WCEC). The proposed WCEC will be an integrated waste management facility that will include waste diversion and recycling operations and as such, this proposed transfer will have an ongoing role in their waste diversion and recycling now and in the future. For example once the WCEC is fully operational, the transfer station may be used to bulk Blue Box recyclables for transfer to a WM owned and operated Materials Recovery facility located off-site.

This Design and Operations Report has been prepared to describe the design of the facility and the on-site operations, which includes:

- a) The receipt, processing and transfer of up to 400 tonnes/day or 124,800 tonnes/year of IC&I and C&D waste material (split in the order of 250 and 150 tonnes/day between the IC&I and C&D waste streams respectively. This assumes all of the 400 daily inbound tonnes are sent to disposal and no portion of it is recovered for reuse/recycling, which is NOT WMCCs intention;
- b) The annual IC&I tonnage fraction (250 tonnes/year) may include between 5,000 and 20,000 tonnes/year of domestic municipal solid waste;
- c) Under a range of potential waste diversion scenarios (20 to 60% of the inbound tonnes of C&D and a smaller portion of the IC&I waste tonnes), the shipment off-site of between 34 and 100 tonnes/day of recovery materials for reuse/recycling;
- d) Under the diversion scenarios mentioned above, the shipment off-site of between 300 and 366 daily inbound tonnes are sent to disposal.

As noted above, WMCC is seeking an amendment to their existing provisional Certificate of Approval (number A461002) for their landfill site to enable the operation of the proposed transfer & processing facility. And, given the existing D&O plan for the landfill site addresses a number of operational issues, which are common to the operation of the proposed transfer facility (e.g., Complaints Procedure, Air Discharges / Dust Control, Litter Prevention and Control) and therefore where appropriate the landfill D&O plan will govern or otherwise supplement this D&O plan.

2. Facility Design/Operations

2.1 Site Location and Land Use

The waste transfer and processing facility is located west of the City of Ottawa in the former Municipality of Carleton. It is located on the Waste Management of Canada Corporation (WMCC) landfill site at 2301 Carp Road. The transfer station will be located at the south - west end of the property backing onto William Mooney Road. Refer to Appendix A figures 1 and 2 which shows its location Regionally as well as its local setting relative to major arterial roads and highways. The proposed site for the transfer station is located directly north of Highway 417 on an existing cleared area of the landfill site which is in the order of 2.3 hectares in size (approximate dimensions 150 x 150 m), refer to Figure 3 (existing building co-ordinates are: 45° - 16' - 33.80" North and 75° - 58' - 19.44" West).

The facility is located on land that is designated as Carp Road Rural Employment Area according to the City of Ottawa 2003 Official Plan with permitted uses including rural industrial and commercial uses. Within a 500 m radius, the only other designation is General Rural Area located on the west side of William Mooney Rd. The permitted uses for General Rural Area includes (but not limited to) uses that are noxious, such as salvage or recycling yards, composting or transfer facilities.

Within the boundary of the current Ottawa Waste Management Facility, there are four different zoning by-laws. The current zoning under the City of Ottawa Comprehensive Zoning By-law for the portion of the Waste Management site where the facility will be located is zoned as Rural Heavy Industrial Zone, subzone 1, with Exceptions, with a holding provision (RH1[269r]-h). The only permitted uses for this zoning are solid waste disposal facility, leaf and yard waste composting facility and waste processing and transfer facility. Facility operation is consistent with the allowable site zoning and surrounding land use. The adjacent portions of the property are zoned as follows:

- **RH** – Rural Heavy Industrial Zone, which permits primary uses such as automobile body shop and service station, crematorium, gas bar, heavy equipment and vehicle sales, rental and servicing, heavy industrial uses, kennel, leaf and yard waste composting facility, light industrial use, parking lot, printing plant, service and repair shop, storage yard, truck transport terminal, warehouse, waste processing and transfer facility. Conditional uses include bank machine, car wash, convenience store, drive-through facility, restaurant (full service or take-out), and retail store.
- **RH1[270r]** – Rural Heavy Industrial, subzone 1 with exceptions, which only permits leaf and yard waste composting facility and waste processing and transfer facility.
- **RH1[200r]** – Rural Heavy Industrial, subzone 1 with exceptions, which only permits leaf and yard waste composting facility, solid waste disposal facility and waste processing and transfer facility.

The Zoning Plan (Appendix A, Figure 3) shows the current zoning in the vicinity of the site.

Existing land uses surrounding the proposed transfer facility include:

- Industrial/Commercial – including the landfill site and two properties south of Highway 417
- Open Space – directly south of Highway 417
- Forest – located on the Ottawa WMF and south of the facility and north of Highway 417
- Residential – four residential properties

Receptors within the 500 m radius include 4 residential homes, 3 of which are on William Mooney Road directly across the street (within 200 m) of the transfer station and one commercial properties south of Highway 417. Receptors are summarized in Table 1 below and shown on Figure 3 (Appendix A).

Table 1. Local Receptors within a 500 m Radius

Receptor	Description	Address	Location Shown on Figure 3	Straight Line Distance
Residential	Single Family owned by Waste Management and rented out	381 William Mooney Road Ottawa ON K0A1L0	1	120 m
Residential	Single Family owned by Waste Management and rented out	365 William Mooney Road, Ottawa ON	2	120 m
Residential	Single Family optioned by Waste Management and owned privately	357 William Mooney Road, Ottawa ON	3	160 m
Industrial	Communication Tower optioned by Waste Management, owned privately (same owners as location 3) and leased to Clearnet	357 William Mooney Road, Ottawa ON	4	330 m
Residential	Single Family owned	292 Moonstone Road, Ottawa ON	5	430 m
Commercial	Cassidy's Cartage and Storage	128 Willowlea Road, Ottawa ON K0A 1L0	6	460 m

2.2 Design Overview

As noted above, WMCC is currently utilizing a competitor's transfer station to manage approximately 100 tonnes/day of their customers IC&I and C&D waste materials. WMCC wants to construct and operate an IC&I and C&D Waste Transfer & Processing Facility to be located in the southwest corner of their landfill site. The two facilities (the IC&I & C&D facilities) will be located adjacent to one another on an existing cleared area on the landfill site approximately 2.3 hectares in size. The facility will process 400 tonnes/day of waste generated from their local IC&I and C&D customers, split in the order of 250 tonnes/day of IC&I and 150 tonnes/day of C&D waste materials.

The detailed design for each of the IC&I and the C&D components of the transfer station is still underway however, for the purpose of this D&O report, the design and operation of each are described below.

2.2.1 IC&I Waste Transfer & Processing Facility

After consideration of a number of options, it was concluded that the most cost effective and expeditious means to create the required IC&I transfer station is to utilize and otherwise convert an existing maintenance shop located in the southwest corner of the landfill site property. The existing buildings dimensions are 21.6 m (70 feet) wide by 29.5 m (100 feet) long, 6.85 m (21.5 feet) from grade to the peak of the roof and 5.5 m (18 feet) from grade to the eaves of the roof. This equates to a building in the order of 635 square metres (7,000 square feet) in area.

The general concept for the conversion project is summarized below and is shown on Figure 4. For the sake of simplifying the discussion that follows, it will be based on reference drawing north (the top of the page) as opposed to true or magnetic north.

- a) Since the height of the existing maintenance shop building is too low to permit clear tipping of waste collection trucks, it will be necessary to construct a new tipping area adjacent to the east end of the existing building. The new IC&I tipping area will be open air (no roof over it). The open air tipping area will consist of a concrete slab and push/wing walls (8 feet high) extending out due east off of the northeast and southeast corners of the existing building. The design of the concrete works associated with the new open air tipping area will include building foundations along the north and south sides of the tipping floor in the event that WMCC decides (in the future) to install a structure (high bay tipping enclosure) over the concrete slab. While the detailed plans for the proposed structure have not been finalized, early indications are the structure would not be fully enclosed. It would be open on its east end and enclosed on its north and south sides including a roof over it. There would be a common opening between the west end of the new structure and the east end of the old structure (the former maintenance building).
- b) The new open air tipping area will be the same width as the existing building (the former maintenance building) which is approximately 22 m wide in its north/south dimension and 18.0 m deep in its east west dimension, or approximately 400 square metres in area.
- c) Waste will be loaded into transfer trailers via a compactor located on the west side of the former maintenance building.

It is proposed that two roll-off bins will be positioned on the tip floor of the IC&I transfer station to facilitate the recovery of OCC and scrap metal. These materials will be culled (manually) off the floor into these dedicated containers.

As part of the former building retrofit, 8 foot high concrete push walls will be installed along the entire length of the south wall as well as a portion of the west and east walls. In addition an 8 foot high concrete push walls will be installed in the vicinity of the northwest corner. The push wall in this area is on a diagonal in order to protect an existing building electrical control panel and water sump/pump currently installed in this area. The push wall on the north side of the building will be a combination 8 foot high poured concrete wall as well low profile pre-cast "Jersey" style barriers.

2.2.2 C & D Waste Transfer and Processing Facility

It is proposed that the entire C&D waste sorting operation will be conducted in the open environment (not under cover). It will consist of a combination of a concrete slab and gravelled area. The concrete pad will serve as a tipping area for the waste collection vehicles as well as a platform to sort the delivered materials using a mobile (combination) grapple/loader. The dimension of the concrete slab will be approximately 12 m in its north/south dimensions and 22 m in its east west dimension.

The grapple/loader will sort the materials on the concrete slab and then transfer the recovered materials to a series of 40 yards roll off containers positioned on a gravel pad located around the perimeter of the concrete slab. In addition, one bunker will be created at the west end of the concrete slab. The bunker will serve as temporary storage area for residue from the C & D waste sorting operations. The bunker will be constructed using stacked mass concrete blocks. As required, the loader used in the IC&I transfer station will remove the residue from the C&D residue bunker and transfer it into the IC&I transfer station where it will be loaded (along with IC&I waste) into transfer trailers.

Approximately eleven 40 yard roll-off containers will be used to store specific materials recovered from the C & D waste sorting operations. These materials include: (roll off container 1) concrete and brick/block, (container 2) scrap metal, (container 3) wood, (container 4) gypsum wall board, three roll off containers for plastic materials (one for plastic pipe, a second for plastic film and a third for all other mixed plastics), (container 8) shingles, (container 9) tires, (container 10) old corrugate cardboard (OCC) and finally a spare container. The eleven bins noted will be used as the basis for the on-site storage calculation presented in Sections 2.6 and 2.7 of this report. However, depending on the waste composition and the opportunity(s) to reuse/recycle additional materials, additional bins may be required (up to a maximum of 6).

It is intended that all of the recyclable materials recovered from both the C&D waste sorting operations as well as from the IC&I operations (scrap metal and OCC) will require further processing for reuse or recycling. Wherever possible, WMCC will utilize these materials as part of their landfill site operations. For example, the concrete and brick/block after crushing could be utilized for on-site roads and the wood waste after shredding could be used as mulch on site. WMCC may utilize external contractors to provide these on-site processing services (chipping wood/crushing brick/block) and/or WMCC may purchase the added processing equipment to conduct these services on-site using their own forces.

2.3 Description of On-Site Operations

2.3.1 Waste Accepted at the Site

All waste received will be non-hazardous solid waste from industrial, commercial and instructional (IC&I) generators including construction and demolition (C&D) waste. Any unacceptable waste that is rejected will be removed by the incoming waste hauler, or will be segregated and managed in accordance with Ontario Regulation 347. All solid, non hazardous waste or recyclables will be loaded into either enclosed transfer trailers or roll-off bins and transported to approved receiving facilities.

2.3.2 Hours of Operation

It is proposed that the hours of operation for the Waste Transfer and Processing Facility will be the same as the hours of operation of the WMCC Ottawa Landfill Site, which are described in the Landfill's Provisional Certificate of Approval No A461002 as follows:

“Waste may be accepted at the site between 6:30 a.m. and 8 p.m. between Monday and Friday inclusive and only between 6:30 a.m. and 6 p.m. on Saturday. No waste will be received or processed on Sunday”.

2.3.3 IC&I Waste Transfer Station

Once the IC&I Transfer Station has been constructed, it will function as follows: waste vehicles (combination front end (44% of the deliveries), rear load (48% of the deliveries) and roll-off trucks (8% of the deliveries)) will back onto the open east end of the new open air tipping area and dump their load. As required, a front end loader will clear the tipping floor and push the material into the southwest corner/along the south wall as well as the northwest corner of the former maintenance shop building for temporary storage. As required, the loader will transfer the waste from the waste storage area and feed the waste into a 14 cubic yard compactor. The compactor will discharge the waste into 120/140 cubic yard trailers. The compactor and the transfer trailers will be located on the west side of the former maintenance shop building on a concrete slab at existing grade. The compactor will NOT be installed in a depressed ramp/loading bay (below existing grade). In addition, the compactor loading bay (compactor and transfer trailer) will not be enclosed/under cover but rather open to the environment over its entire length.

Waste will be feed into the compactor via a fully enclosed metal chute/shroud arrangement, the discharge end of which will sit on top of the charging hopper of the compactor. The throat/feed/charging end of the chute/shroud will be installed through an opening located in the middle of the west wall of the building. A high lift loader will be used to feed the waste into the throat/opening of the chute/shroud which will direct the waste to the top of the compactor.

As required, the bins containing the recovered OCC and scrap metal will be removed and shipped to market and empty bins replaced on the slab for further recovery of these materials.

2.3.4 C&D Waste Processing & Transfer Facility

Operationally, the C & D transfer station will function as follows: The waste collection vehicles (100% roll off trucks) will back onto the slab and dump their load. A mobile grapple/loader will then sort through the pile of material and move each of the recovered materials to their dedicated roll-off container or bunker in the case of residue. When quantities justify, the segregated materials will be transferred off-site to market.

As required, the loader utilized in the IC&I waste transfer station will transfer the residue stored in the C&D residue bunker to the IC&I transfer station, where it will be mixed with the IC&I waste and loaded into the compactor/transfer trailer for disposal off-site.

2.3.5 Other Existing Facilities On-Site

As noted earlier the existing maintenance shop will be converted from its current use to house a portion of the waste transfer operations. Attached to the southwest corner of the existing maintenance shop is a portable style structure that is currently being used as a combination wash/change/storage room for the maintenance shop. Given the proposed location/orientation of the compactor and the transfer trailer, it will be necessary to relocate this structure around the corner to the south wall. There is an existing well located in the northwest corner of the former maintenance building. This well provides non-potable water to the wash/change room. In addition there is an existing septic tank and tile field running east west off of the south wall of the existing building. Once the wash/change/storage structure has been relocated it will be reconnected to the water supply and septic system.

There is an existing propane storage tank located near the northwest corner of the former maintenance building. Given that the proposed IC&I transfer station is not fully enclosed, it is likely that the existing building heating system in this building will be abandoned and this tank will be removed

Northwest of the proposed IC&I transfer station is another existing building on the site. This building is currently being used to store materials and will not be used as part of the proposed transfer station operations. To the east of this building is an existing stormwater pond. The pond will be utilized in the site drainage system once the transfer station has been implemented. Refer to Appendix B for a more detailed description of the site grading and drainage system.

On the east side, southeast corner of the existing maintenance shop there is an existing fuel dispensing pump. This pump will be relocated to the south side of the existing building where the existing buried fuel storage tank is located.

2.3.6 Scale House

The landfill's existing weigh scale facility will be utilized as part of the transfer stations operations. The existing scale facility includes a scale house and two 70 foot scales (inbound and outbound scale). The scale is located at the entrance to the landfill site off of Carp Road.

2.4 Vehicle Traffic

As background to the section that follows, in 2005, (when the landfill site was managing approximately 400,000 tonnes/year) a Traffic Condition Assessment Report was carried out for the Ottawa landfill site (using data supplied by WMCC). The report indicated between January 1 and December 31, 2005, the average daily and peak hour landfill site related trips were between 184 and 230 trips/day or between 26 and 38 trips/peak hour.

Currently there are between 350 and 400 loads/month of waste delivering the 100 tonnes/day of waste to their (WMCC) competitor's transfer station (or between 15 and 17 vehicles/day based on 24 days/month). In addition, there would be a further 3 to 4 transfer trailers loads leaving the transfer station site to the disposal site (assuming an average weight of 30 tonnes/53 foot transfer trailer). In total, the current 100 tonnes/day generates between 18 and 21 vehicles/day to collect and dispose of this material.

It is difficult to provide an estimate of the traffic impact for a variety of reasons. A few of the key factors include:

- a) It is a function of the type/composition of waste collected (IC&I and C&D);
- b) The actual quantity of each waste type collected;
- c) The type of vehicle used to collect the waste and the vehicles' weight; and
- d) Hours of operation (hours/day/days/week) to name a few.

Notwithstanding the forgoing, using the assumptions noted below an estimate of the traffic count was prepared.

- a) It is based on a total combined tonnage of 400 tonnes/day of waste materials delivered to the transfer station 6 days a week, Monday to Saturday and the hours of operation as noted in Section 2.3.1;
- b) The split between IC&I and C&D of the 400 tonnes will be variable, however, for the purpose of this report it has been assumed that it is split 250 and 150 tonnes/day respectively;
- c) The waste composition/characterization for both the IC&I and the C&D waste streams are based on the City of Ottawa's 2006 waste characterization study;
- d) The only materials recovered from the IC&I waste stream are cardboard and scrap metal that is easily culled off the floor of the IC&I tipping floor;
- e) The materials recovered from the C&D waste stream includes: wood, asphalt paving, asphalt, tires, roofing, scrap metal, concrete/brick and block, old corrugated cardboard, drywall and plastics (as film, plastic pipe and finally as all other mixed plastics);
- f) Recognizing the difficulty in predicting recovery for reuse and recycling it has been assumed that between 20% and 60% of the 150 tonnes/day of C&D wastes are recovered (for reuse/recycling) and the balance is sent to disposal via the compactor in the IC&I transfer station;
- g) Of the 250 tonnes/day of inbound IC&I waste materials only OCC and scrap metal are recovered for reuse/recycling.
- h) Of the 250 tonnes/day of IC&I waste materials managed at the transfer station/day they are delivered using a combination of front end trucks (delivering 44% of the 250 tonnes/day of IC&I waste), roll-off trucks (delivering 48% of the 250 tonnes/day of IC&I waste) and finally rear load packers (delivering 8% of the 250 tonnes/day of IC&I waste materials). Each type of truck has an average weight of 9, 5 and 6 tonnes respectively;

- i) All C&D waste materials are delivered to the site using roll-off trucks, with an average weight of 2.5 tonnes/load;
- j) All recovered materials will be shipped off-site in roll-off containers; and
- k) All disposed tonnes will be shipped off-site in enclosed transfer trailers.

Table 2. Summary of In/Outbound Vehicle Counts Per Hour & Per Day (at 20% recovery for reuse/recycling)

Vehicle Type	Vehicles/hour	Vehicles/day
Inbound IC&I Delivery Vehicles	3.3	40
Inbound C&D Materials	5	60
Outbound Transfer Trailers	1	12
Outbound C&D Recyclables	0.5	6
Outbound IC&I Recyclables	0.2	2
Totals	10	120

Refer to Table C1 in Appendix C for the details associated with the above summary table.

Table 3. Summary of In/Outbound Vehicle Counts Per Hour & Per Day (at 60% recovery for reuse/recycling)

Vehicle Type	Vehicles/hour	Vehicles/day
Inbound IC&I Delivery Vehicles	3.3	40
Inbound C&D Materials	5	60
Outbound Transfer Trailers	0.8	10
Outbound C&D Recyclables	1.6	19
Outbound IC&I Recyclables	0.6	6
Totals	11	135

Refer to Table C2 in Appendix C for the details associated with the above summary table.

Table 4. Range of In/Outbound Vehicle Counts Per Hour & Per Day (between 20 and 60% recovery for reuse/recycling)

Vehicle Type	Vehicles/hours	Vehicles/day
Inbound IC&I Delivery Vehicles	3.3	40
Inbound C&D Materials	5	60
Outbound Transfer Trailers	0.8 - 1	10 – 12
Outbound C&D Recyclables	0.5 – 1.6	6 – 19
Outbound IC&I Recyclables	0.2 – 0.6	2 – 6
Totals	10 - 11	120 - 135

Under both recovery scenarios (20 and 60% of the C&D waste stream), the traffic impact is significantly less than the traffic impact associated with landfill site operations in 2005, when the site was managing in the order of 400,000 tonnes/year.

2.5 Material Balance

Using the assumptions made and the data generated for Section 2.4 Vehicle Traffic above, most notably the tables contained in Appendix C, the Process Schematic (figure 6 in Appendix A) was created. As noted earlier, given the variability in the composition as well as the split between IC&I & C&D waste streams, it is difficult to predict and otherwise commit to an overall diversion target. However, for the purpose of this D&O report and as a means to determine a range of tonnage of materials that could be diverted tables C1 and C2 in Appendix C were prepared.

The results of which are summarized below.

	Total Material Diverted/Disposed (based on 20% recovery of the C&D Recyclables) (tonnes/day)	Total Material Diverted/Disposed (based on 60% recovery of the C&D Recyclables) (tonnes/day)
C&D Material (Diverted)	27	80
C&D Disposed	124	71
IC&I (Diverted)	7	22
IC&I (Disposed)	242	227
Total (tonnes/day)	400	400

As can be seen, at the 20% diversion rate, approximately 34 tonnes/day are diverted and 366 tonnes/day are disposed. At the 60% diversion rate, approximately 100 tonnes/day are diverted and 300 tonnes/day are disposed.

2.6 On-Site Material Storage

Appendix D contains the on-site storage calculations and are summarized below:

Table 5. On-Site Storage

Storage Areas	Storage Capacity (cubic metres)	Storage Capacity (tonnes)
IC&I Transfer Station		
Storage Capacity along the South Wall of the Tip Floor	430	103
Storage Capacity in the NW Corner of the Tip Floor	66	16
Waste Storage Capacity in the IC&I Transfer Station	500 (rounded)	120 (rounded)
Scrap Metal Roll-off Bin	40	5
OCC Roll-off Bin	40	2.5
Total Waste & Recyclable Storage Capacity	580	128
C&D Processing Area		
Scrap Metal Roll off Bin	40	5
Concrete/Brick/Block	40	5
Wood Roll-off Bin	40	5
Plastic Pipe Roll-off Bin	40	2.5
Drywall Roll-off Bin	40	5
Plastic Film Roll-off Bin	40	2.5
Mixed Plastics Roll-off Bin	40	2.5
Shingles Roll-off Bin	40	5
Tires Roll-off Bin	40	5
OCC Roll off Bin	40	2.5
Spare Roll-off Bin	40	5
Residue Storage Bunker	27	6.4
Total Waste Storage Capacity on the slab/in bins/bunker around the C&D waste processing area	470 (rounded)	60 (rounded)

2.7 Site Storage

Waste is stored in accordance with Section 3.3.2 of the Ontario Fire Code, which stipulates the requirements for indoor general storage of combustible or non-combustible solids. In particular, storage complies with the following:

- The area of an individual storage pile does not exceed 1,000 m²;
- The maximum permitted height of storage for any individual storage area will be 4.5 m; and
- At least one main aisle with a minimum width of 2.4 m extends the length of each storage area and to fire protection equipment.

The maximum amount of waste stored on site is 126 tonnes of waste (120 IC&I and 6.4 C&D) and the maximum amount of recyclable material to be stored on site is 60 tonnes (7.5 IC&I & 53.6 C&D), as supported by the calculations of Storage Capacity included in Appendix D. The recyclable tonnes assume all of the on-site roll off bins, 13 of them are full

All solid, non-hazardous waste received on site will be removed within 72 hours of receipt. Recyclable material destined for further processing will be retained on-site until sufficient quantity has accumulated to make it economic feasible to transport material.

Table 6 provides a summary of the maximum amount of the various waste streams that would be present or stored at the site.

Table 6. Summary of the Maximum Amount of Various Waste Streams Present or Stored on Site

Waste Streams	Received (tonnes per day)	Total Available Storage Capacity (cubic metres)	Total Available Storage Capacity (tonnes)	Final Disposal (tonnes per day)
IC&I Materials				
Waste (potential inbound)	250	500	120	
Recyclables	7-22	80	7.5	
Range of Potential Outbound Waste	227-243	580	128	227-243
C&D				
Waste (inbound)	150	27	6.4	
Recyclables	27-80	443	53.6	
Range of Potential Outbound Waste	71-124	470	60	71-124
Grand Total	400	1050	188	300-367

Assuming: a duty and a standby transfer trailer is available at all times during the day;
an average weight/trailer of 30 tonnes;
an average “hook to hook” time of between 45 and 60 minutes, and
an average duration of daily operation of 12 hours.

The transfer operation has a capacity of between 12 and 16 loads/day or **360 and 480 tonnes/day**. Based on the forgoing the transfer station has the capacity to manage the outbound tonnes under the 20% diversion scenario (367 tonnes/day) up to complete by pass of recovery for reuse/recycling or 400 tonnes/day.

In the event that the compactor is down or transfer trailers are not available for longer than approximately 3 to 4 hours, WMCC will adopt one or a combination of the following alternative actions to manage the waste stream(s) during this period:

- Divert inbound collection trucks to alternative transfer/disposal location;
- Using their own forces/rolling stock or other local area waste haulers utilize open top trailers to transfer the waste.

2.8 Fencing and Security

The landfill site, including the proposed site for the transfer station is completely fenced. Access to the site will be via the main entrance off of Carp Road. All in/outbound traffic will be required to scale in/out. There is an entrance to the transfer station site off of William Mooney Road. However this entrance is routinely locked.

2.9 Facility Equipment and Maintenance

The specific pieces of equipment to be utilized at the proposed transfer station have not been specified or purchased. However it is anticipated that a large solid tire high lift loader (for the IC&I waste transfer operations) as well as a combination grapple/loader (for the C&D waste operations) and a 14 cubic yard waste compactor unit will be required as part of the waste transfer and processing operation. Operators of this equipment are trained on the safe operating practices. Preventative maintenance programs are in place for this equipment in accordance with manufacturer's recommendations. The types of heavy equipment used on site may vary.

2.10 Staff Training

A training plan has been developed and maintained for all employees that operate the facility. Trained personnel will be on duty at all times when the facility is open to ensure proper supervision of all activities. Trained personnel will supervise all receiving and transfer of waste at the facility. All employees directly involved with activities related to the facility are trained in the following:

- Relevant waste management legislation, regulations and guidelines
- Major environmental concerns pertaining to the waste to be handles;
- Occupational health and safety concerns pertaining to the processes and wastes to be handled;
- Management procedures including the use and operation of equipment for the processes and waste to be handled;
- Emergency response procedures for the processes and wastes to be handled;
- Use and operation of the equipment to be used;
- Procedures for the refusal of unacceptable loads;
- Specific written procedures for the control of nuisance conditions;
- Record keeping procedures; and,
- The requirements of the Certificate of Approval.

Waste Management of Canada will maintain a written record of employee training.

2.11 Waste Screening Procedure

Waste is only accepted from approved haulers that have a valid Waste Management System Certificate of Approval, except for vehicles as per Section 16(2)(a) of Regulation 347.

All inbound waste vehicles must enter over the weight scale where they are directed to the appropriate receiving area. A sign listing the non-acceptable wastes is erected prior to entrance of the facility. The scale operator screens the waste verbally when the vehicle is inbound to the facility. All unloading operations are under supervision of trained WMCC employees to prevent deposition of any unauthorized wastes. All outbound vehicles scale out on the outbound scale prior to exiting the site.

Should unacceptable waste be deposited at the facility, it will be reloaded and removed from the site on the delivering waste collection vehicle. In the unlikely event that unacceptable or prohibited waste is not detected until after the depositing waste vehicle has left the facility, the waste will be segregated, characterized and managed in accordance with Ontario Regulation 347. A waste discrepancy form will be completed by a trained WMCC employee and retained on site. Efforts will be made to identify and inform the customer to ensure the situation is not repeated.

2.12 Environmental/Emergency Measures

2.12.1 Stormwater Management

Refer to Appendix B for the detailed assessment of the drainage impacts of implementing the proposed transfer station.

In summary "Based on the analysis (contained in Appendix B), it can be concluded that the proposed modifications to the site to facilitate the new Transfer Station would have negligible impact on local drainage".

2.12.2 Air Discharge/Dust Control

There are two types of air discharges that have been considered in the operation of this facility, these include odour and dust.

C&D materials such as concrete, brick, block, asphalt and wood are typically not odourous. It is not anticipated that these material will generate odours but should these materials become odourous, they will be shipped from the site on a more frequent basis, as needed.

Typically nuisance dust is generated by truck traffic on unpaved, dry surfaces. Since the areas where trucks and tractor-trailers travel on-site is unpaved, dust generation could be a concern at the facility. Should dust become a problem, dust suppression will be applied.

The storage portion of the IC&I transfer station (the former maintenance shop) will be equipped CO2 and methane detection sensors.

2.12.3 Spills

Spills management will be in accordance with the applicable section in the existing landfill D&O plan.

2.12.4 Fire

The existing maintenance building is a single storey structure, approximately 650 m² (7,000 ft²) in total building area, metal cladding on steel structure.

Referring to the Ontario Building Code, based on the building area and use, the building in question can be classified under 3.2.2.80 Group F, Division 3, One storey, non sprinklered (combustible or non-combustible construction used singles or in combination provided that it is not more than one storey and has a building area not more than 5,600 m² if facing one street).

Based on the foregoing, the building does not need to be sprinklered, and therefore multipurpose fire extinguishers will be utilized.

2.13 Site Inspections and Nuisance Conditions

2.13.1 Odour Prevention and Control

Waste Management has an established litter management plan in place as part of their former landfill site operations.

As it relates to the proposed transfer and processing facility, the site will be inspected daily to assess nuisance conditions, including odours. If odours are detected, an odour suppressant will be applied to the waste in the materials storage area of the IC&I transfer building and/or the odourous waste will be removed from the site as soon as possible. If odourous waste is repeatedly received from a particular generator that cannot be managed at the facility, the waste will no longer be accepted from that customer.

2.13.2 Litter Prevention and Control

Waste Management has an established litter management plan in place as part of their former landfill site operations. This will form the basis for a litter prevention and control plan to be developed as part of transfer station operations. For example, the use of portable litter fences may be required

It is acknowledged, given both tipping floors (the IC&I and C&D) are open air, there may be a problem with blowing litter. The strategy to minimize this problem, in the case of the IC&I tip floor, will be to move the materials off the tip floor into the enclosed portion of the building (the former maintenance shop) as soon as possible. And, in the case of the C&D tip floor, the site operators need to process the materials and deposit them in their dedicated roll off containers as soon as possible.

And finally if litter is routinely or intermittently a problem, Waste Management will have to deploy staff to recover the litter before it blows off-site.

2.13.3 Vermin Control

If required, Waste Management will retain a professional pest control company to implement and oversee a pest control program at the site.

2.14 Complaint Procedure

Complaint procedures will be in accordance with the applicable section in the existing landfill D&O plan.

2.15 Record Keeping

Records (either electronic or hardcopy) will be kept of all incoming and outgoing materials at the facility, including:

- Record of any rejected waste;
- Type, date, time of arrival, source and quantity of waste received;
- Company name of hauler delivering the waste;
- Certificate of Approval number of hauler, except if the hauler is a municipal vehicle;
- Daily Site Operations Inspection Reports and Complaint Logs;
- Calculation of quantity of waste remaining on-site at the end of each operating day; and
- Type, date, time, destination and quantity of material shipped.

An Annual Report will be submitted to the District Office of the MOE. Each report includes the following information:

- Detailed monthly summary of the type, and quantity of all wastes received at the site;
- Detailed monthly summary of the type, and quantity of all wastes shipped from the site and the location to which it was shipped;
- A description of any operational issues encountered;
- Amount of recovered recyclables shipped to market;
- Amount of residual waste shipped to landfill;
- Average daily amount of waste received and shipped; and
- Amount of waste stored on site as of date of preparation of Annual Report.

2.16 Waste Receiving Sites

The waste from the proposed transfer station will be disposed in other permitted landfills in Ontario or in the northeastern United States. These landfills may be owned/operated by Waste Management or by others.

Currently Waste Management of Canada is utilizing the following approved receiving sites:

- Lefleche Environmental Inc, Moose Creek, Ontario (Certificate of Approval A420018)
- Petrolia Landfill, Petrolia, Ontario (Certificate of Approval A030303)
- The Ridge, Chatham, Ontario (Certificate of Approval A021601)
- Richmond Landfill, Napanee, Ontario (Certificate of Approval A371203)
- Pine Tree Acres Landfill, Michigan (License Number 9045)

2.17 Disruption of Shipment

Should there be a disruption of shipment; the site will be able to continue to accept waste until the facility meets its storage capacity, which is less than the permitted receiving quantity of 400 tonnes of waste per day. At that time, the site will not accept additional waste. If the shipment disruption continues such that the maximum storage time of 72 hours will be exceeded, Waste Management of Canada Corporation will contact other waste transportation service companies to ensure waste is removed from the site.

2.18 Decommissioning Plan

Should the site be no longer needed, it will be decommissioned prior to a change in use or sale of the property. If it is determined that the facility will close, a site assessment will take place and a decommissioning plan will be completed six months prior to site closure.

The decommissioning will include the following procedures:

- All waste material storage areas will be emptied and waste sent for disposal;
- All on-site equipment will be removed from the site and either sold or reused at another Waste Management facility;
- All floors will be swept and, if necessary, power washed and any wastewater would be collected and disposed in accordance with Ontario Regulation 347; and
- The exterior portions of the site will be cleaned of any litter.

2.19 Financial Assurance

Given the basis for the approval for the proposed facility is to amend the current Certificate of Approval for the landfill site, it is proposed that the financial assurance for the landfill site will be increased as shown below, once the application for the proposed transfer station has been approved.

Proposed increase in financial assurance is \$52,000 which will cover the cost of loading, trucking (in-roll-offs) 600 tonnes of waste stored on-site to some other licensed disposal facility.

Appendix A

Figures

Figure 1. Site Location Plan, Regional Setting

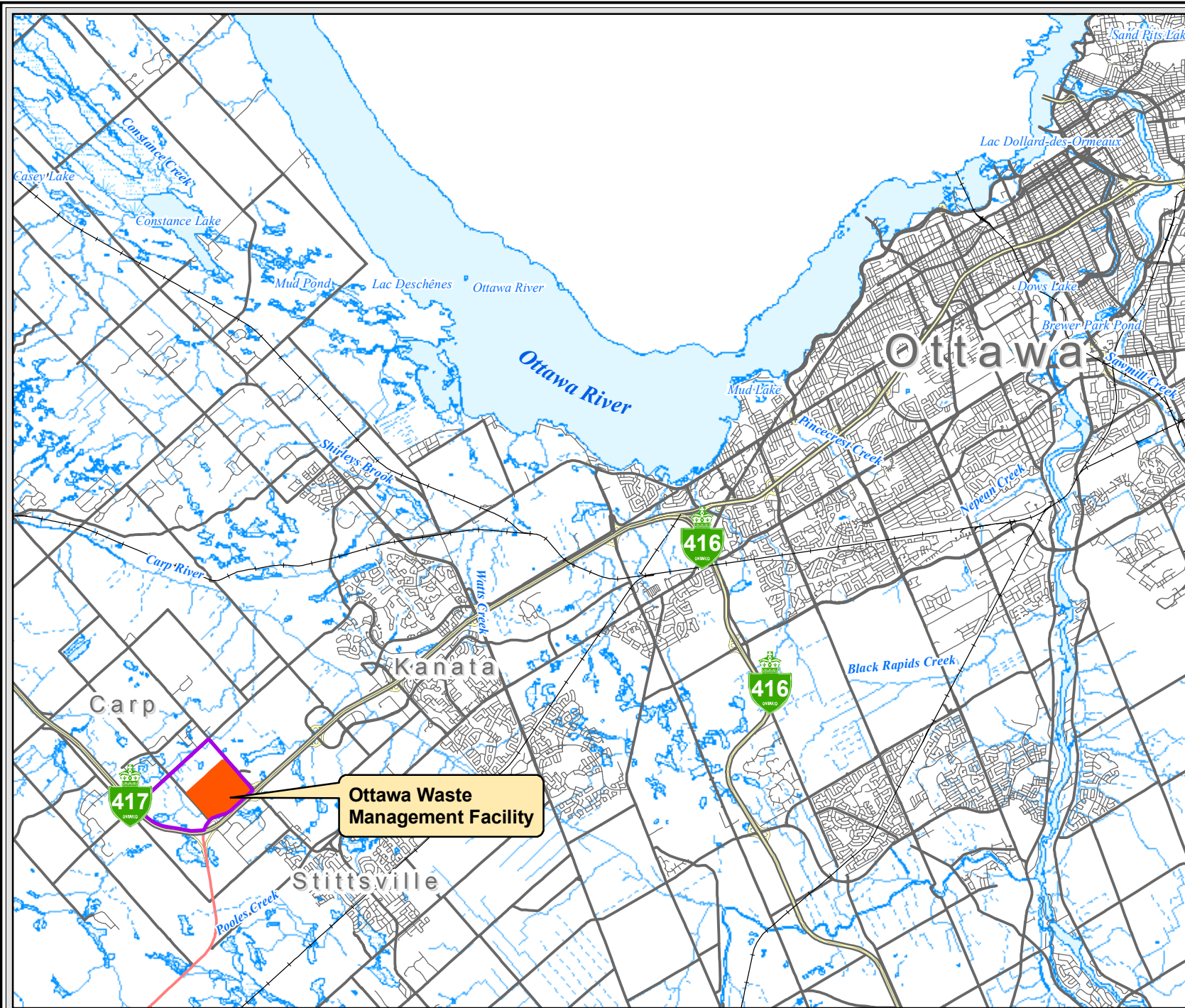
Figure 2. Site Location Plan, Local Setting

Figure 3. Land Use Zoning & Local Receptors

Figure 4. Site Layout

Figure 5. Facility Layout

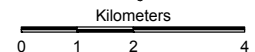
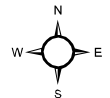
Figure 6. Process Schematic



Legend

- Lands In The Vicinity of The WM Ottawa WMF
- Current Landfill Site
- Property Boundary

Basemapping from Ontario Ministry of Natural Resources



1:135,000

UTM Zone 17N, NAD 83

This drawing has been prepared for the use of AECOM's client and may not be used, reproduced or relied upon by third parties, except as agreed by AECOM and its client, as required by law or for use by governmental reviewing agencies. AECOM accepts no responsibility, and denies any liability whatsoever, to any party that modifies this drawing without AECOM's express written consent.

Waste Management of Canada Corporation - Ottawa Waste Transfer and Processing Facility

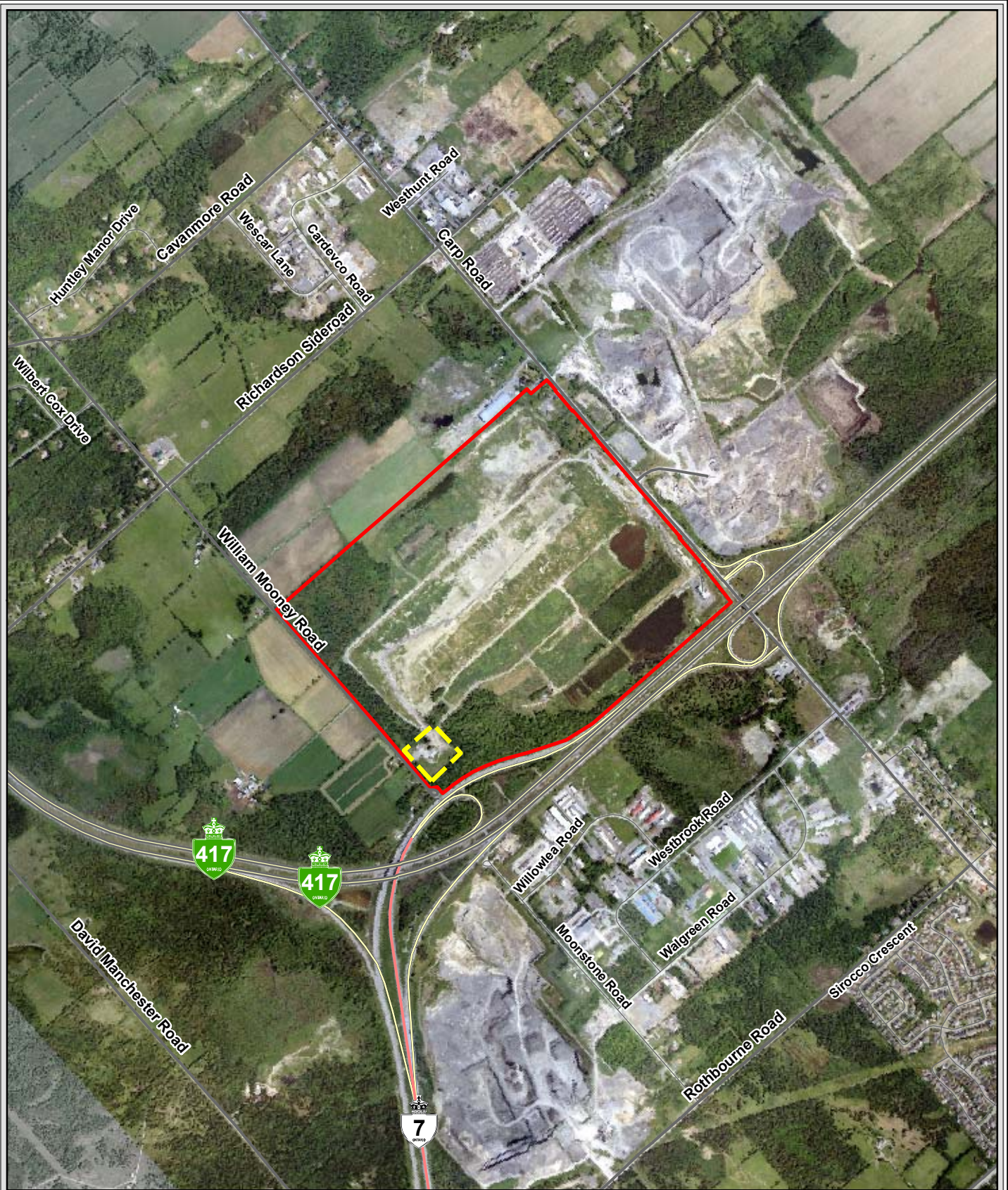
**Site Location Plan
Regional Setting**

February 2011
Project 60191228-15

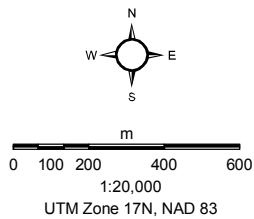


Figure 1

Map Document: N:\projects\0_aecom\60116860\2009\Final\GIS\Spatial\MXD\Working\MXDs\60116860\Site\LocationPlanLocalSetting.mxd
02/16/2011 -- 5:42:25 PM



Basemapping from Ontario Ministry of Natural Resources
Orthophotography: 2010



Legend

-  Current Ottawa WMF Operations
-  Proposed Waste Transfer and Processing Facility

Waste Management of Canada Corporation - Ottawa Waste Transfer and Processing Facility

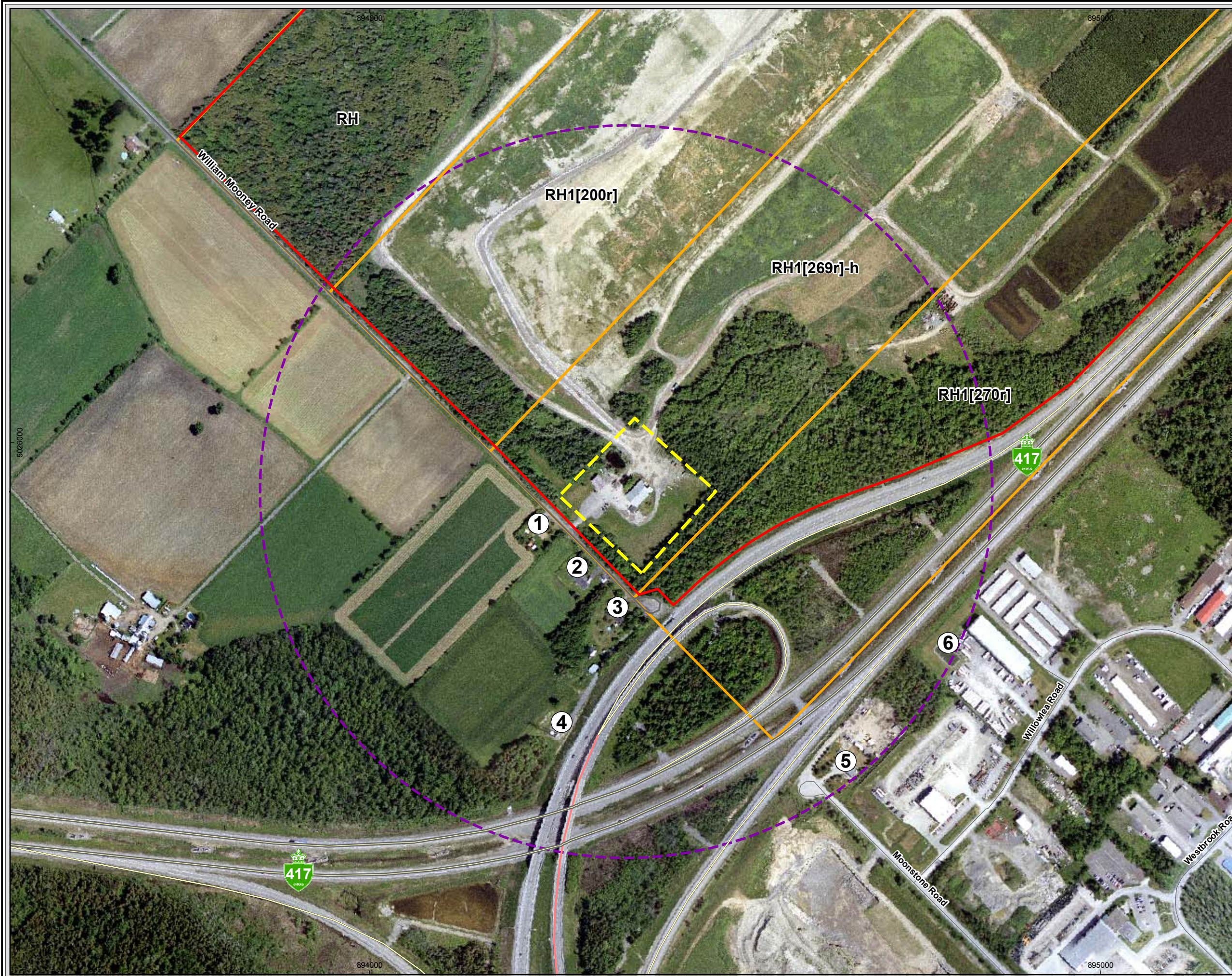
Site Location Plan Local Setting

February 2011
Project 60191228-15



Figure 2

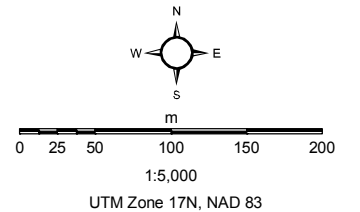
Map Document: (N:\projects\0-ae.com\60116860\2011\Final\GIS\Spatial\MXDs\Working\MXDs\60116860ReceptorLocation500m.mxd)
02/16/2011 3:47:03 PM



- Legend**
- Site Limits (2.26 ha.)
 - 500 m Buffer
 - Current Ottawa WMF Operations
 - Boundary of Zoning Bylaw
 - ① Receptor Location



Basemapping from Ontario Ministry of Natural Resources
Orthophotography: 2010



This drawing has been prepared for the use of AECOM's client and may not be used, reproduced or relied upon by third parties, except as agreed by AECOM and its client, as required by law or for use by governmental reviewing agencies. AECOM accepts no responsibility, and denies any liability whatsoever, to any party that modifies this drawing without AECOM's express written consent.

Receptor Locations and Zoning

February 2011
Project 60191228-15


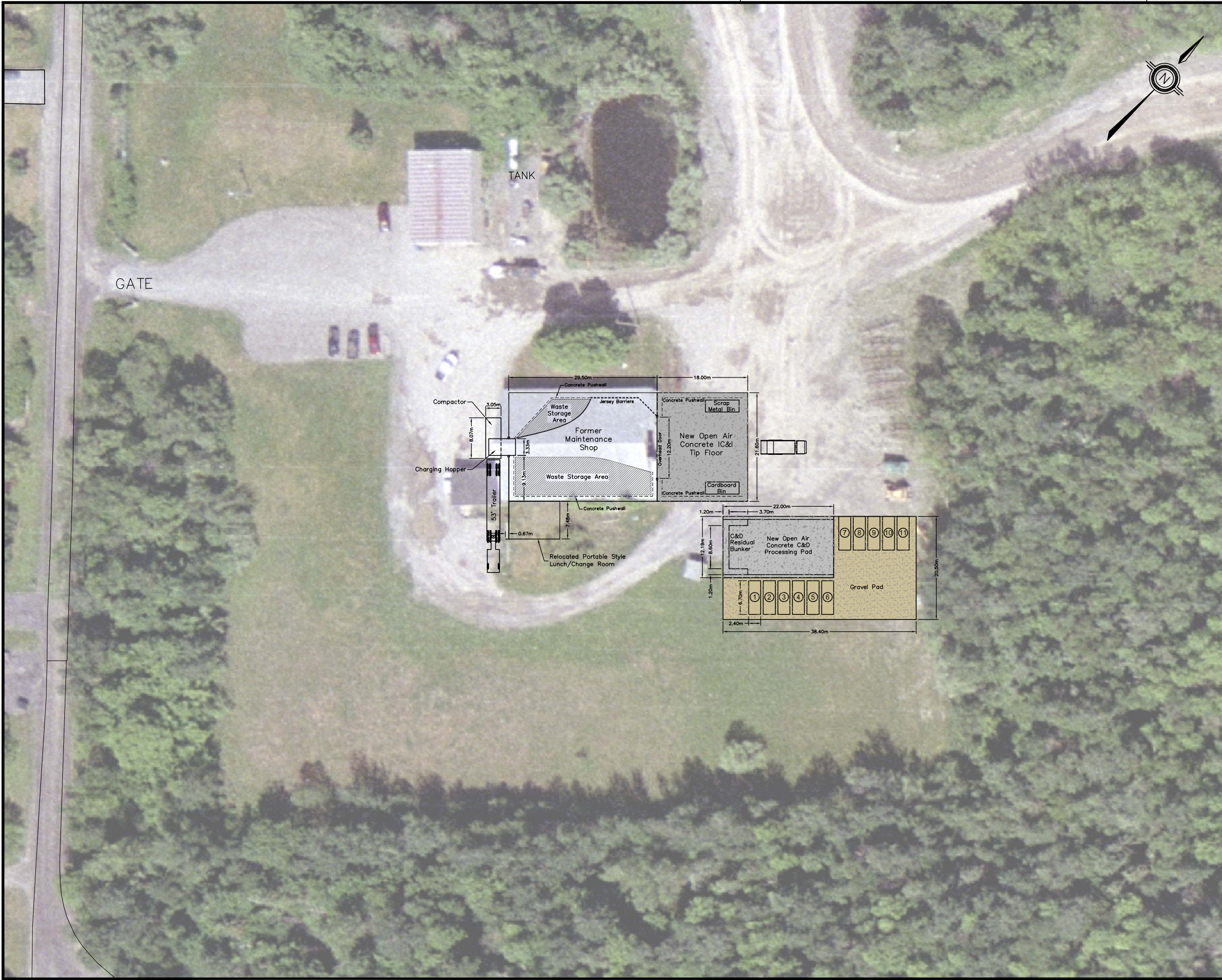


Figure 3

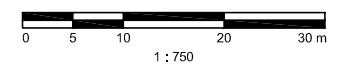
B SIZE 11" x 17" (279.4mm x 431.8mm)

PLOT: 2/16/2011 12:56:18 PM

FILE NAME: 60191228-15-FIG04.DWG



Legend



DO NOT SCALE THIS DOCUMENT.
ALL MEASUREMENTS MUST BE OBTAINED FROM STATED DIMENSIONS.

This drawing has been prepared for the use of AECOM's client and may not be used, reproduced or relied upon by third parties, except as agreed by AECOM and its client, as required by law or for use by governmental reviewing agencies. AECOM accepts no responsibility, and denies any liability whatsoever, to any party that modifies this drawing without AECOM's express written consent.



**Waste Management of Canada Corporation
Ottawa Waste Transfer & Process Facility**

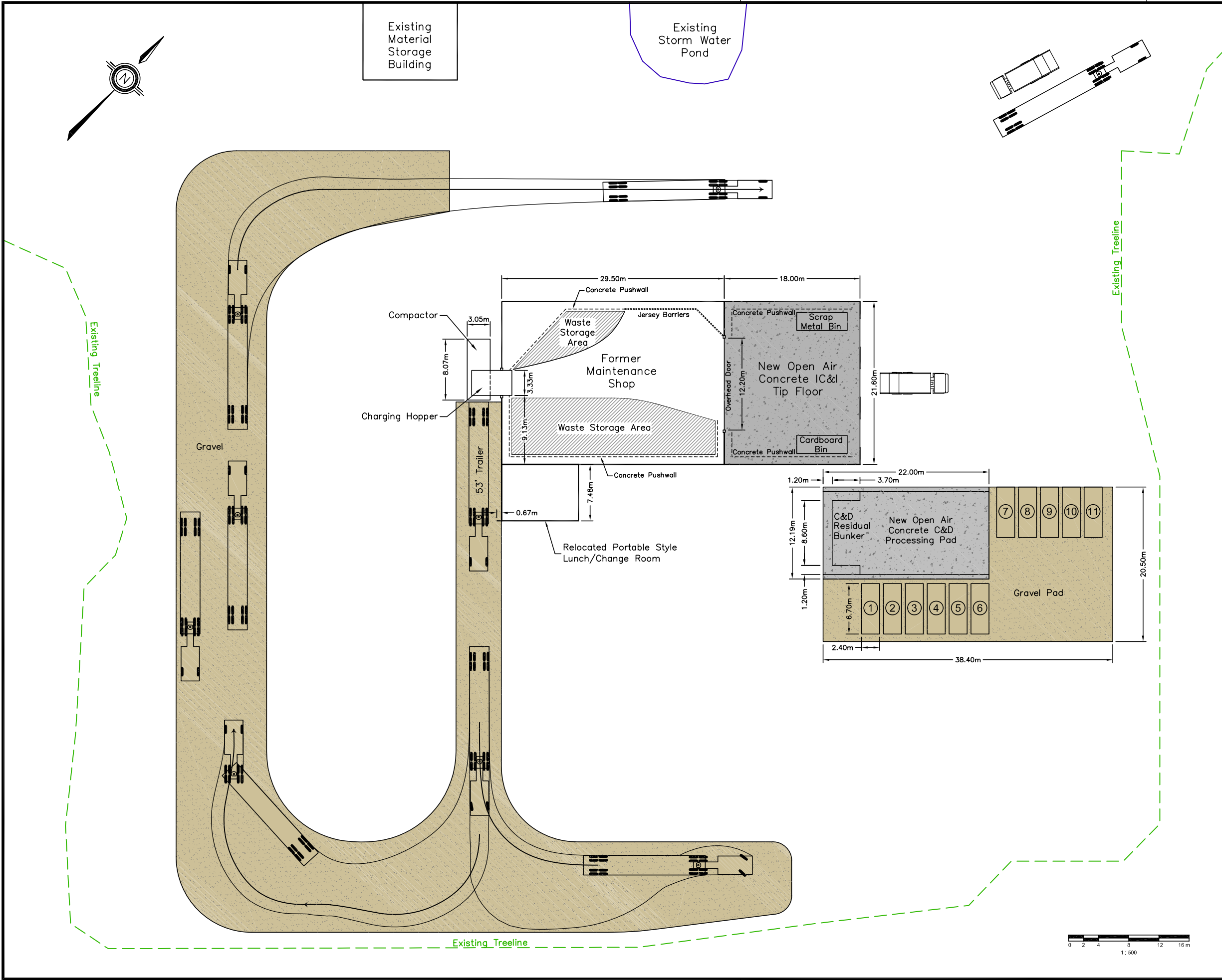
Site Layout

PROJECT NUMBER	DATE	FIGURE
60191228-15	February, 2011	4

B SIZE 11" x 17" (279.4mm x 431.8mm)

PLOT: 2/16/2011 1:25:30 PM

FILE NAME: 60191228-15-FIG05.DWG



Legend

- ① Concrete / Brick / Block
- ② Scrap Metal
- ③ Wood
- ④ Gypsum
- ⑤ Plastic Pipe
- ⑥ Plastic Film
- ⑦ Mixed Plastics
- ⑧ Shingles
- ⑨ Tires
- ⑩ OCC
- ⑪ Spare

■ Concrete

■ Gravel

DO NOT SCALE THIS DOCUMENT.
ALL MEASUREMENTS MUST BE OBTAINED FROM STATED DIMENSIONS.

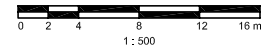
This drawing has been prepared for the use of AECOM's client and may not be used, reproduced or relied upon by third parties, except as agreed by AECOM and its client, as required by law or for use by governmental reviewing agencies. AECOM accepts no responsibility, and denies any liability whatsoever, to any party that modifies this drawing without AECOM's express written consent.

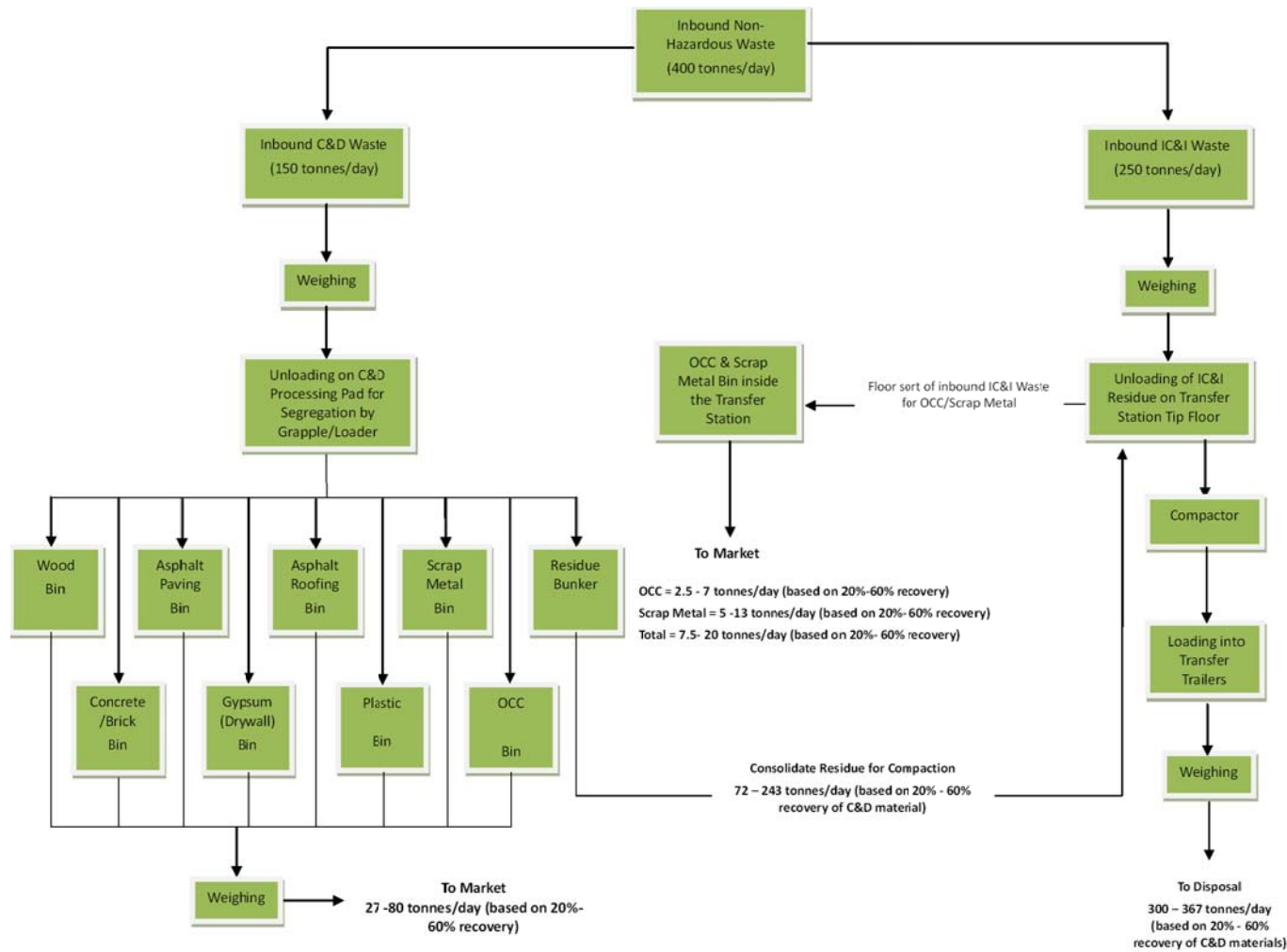


**Waste Management of Canada Corporation
Ottawa Waste Transfer & Processing
Facility**

Facility Layout

PROJECT NUMBER	DATE	FIGURE
60191228-15	February, 2011	5





Legend

DO NOT SCALE THIS DOCUMENT. ALL MEASUREMENTS MUST BE OBTAINED FROM STATED DIMENSIONS.



**Waste Management of Canada Corporation
Proposed Ottawa IC&I / C&D Transfer and
Processing Facility**

**Design and Operations Report
- Process Schematic**

PROJECT NUMBER	DATE	FIGURE
60191228-15	February 2011	6

This drawing has been prepared for the use of AECOM's client and may not be used, reproduced or relied upon by third parties, except as agreed by AECOM and its client, as required by law or for use by governmental reviewing agencies. AECOM accepts no responsibility, and denies any liability whatsoever, to any party that modifies this drawing without AECOM's express written consent.

Appendix B

Drainage Study

To Shawn Z., P.Eng, AECOM
Robert Lippet, P.Eng., AECOM

Page 1

CC

Subject WMI – Carp Road Landfill – Transfer Station
UPDATED Drainage Requirements

From Paul Frigon, P.Eng., AECOM
Chris O'Donnell, EIT, AECOM

Date February 16th, 2011

Project Number 60191228

A Transfer Site is being proposed in the Southwest sector of the WMI's Carp Landfill site to accommodate Industrial, Commercial and Institutional (ICI) waste as well as waste from Construction and Demolition (C+D). Both the existing and proposed drainage for the proposed Transfer Station site is illustrated in **Figure 1**. The site under consideration is approximately 3.0 ha in area and is centered at a high point in the local topography. It drains:

- Catchment A - East, overland, to an existing watercourse that drains to a surface water storage /treatment pond,
- Catchment B - South, overland, to a ditch adjacent to a Highway 417 off-ramp and
- Catchment C - West, overland, to the William Mooney Road roadside ditch that eventually drains to Huntley Creek.

The site currently contains a former Maintenance Shed as well as a system of compacted gravel roadways and parking lots. In the past, a sump in the shed was used to collect any washwater or other liquids from the shed floor that would then be pumped to a small 0.04 ha on-site storage pond to the north of the site. This pond is lined and has no outlet: its contents were periodically pumped to a tanker truck and the liquid disposed of in a leachate control pond in the Southeast sector of the landfill site.

The proposed Transfer Station will include: the former Maintenance Shed which will be converted to an ICI transfer station; a new adjacent slab which will serve as a tipping floor; a new adjacent compactor; a new open-air concrete C+D sorting pad; a gravel pad, adjacent to the C+D concrete pad, to store recycling bins and provide vehicle access; and additional gravel roadways and parking lots for site access. This change in landuse will result in minor changes in runoff for the site, but the impacts on water quality and water quantity have been determined negligible, as discussed below.

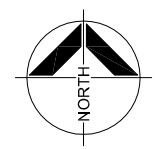
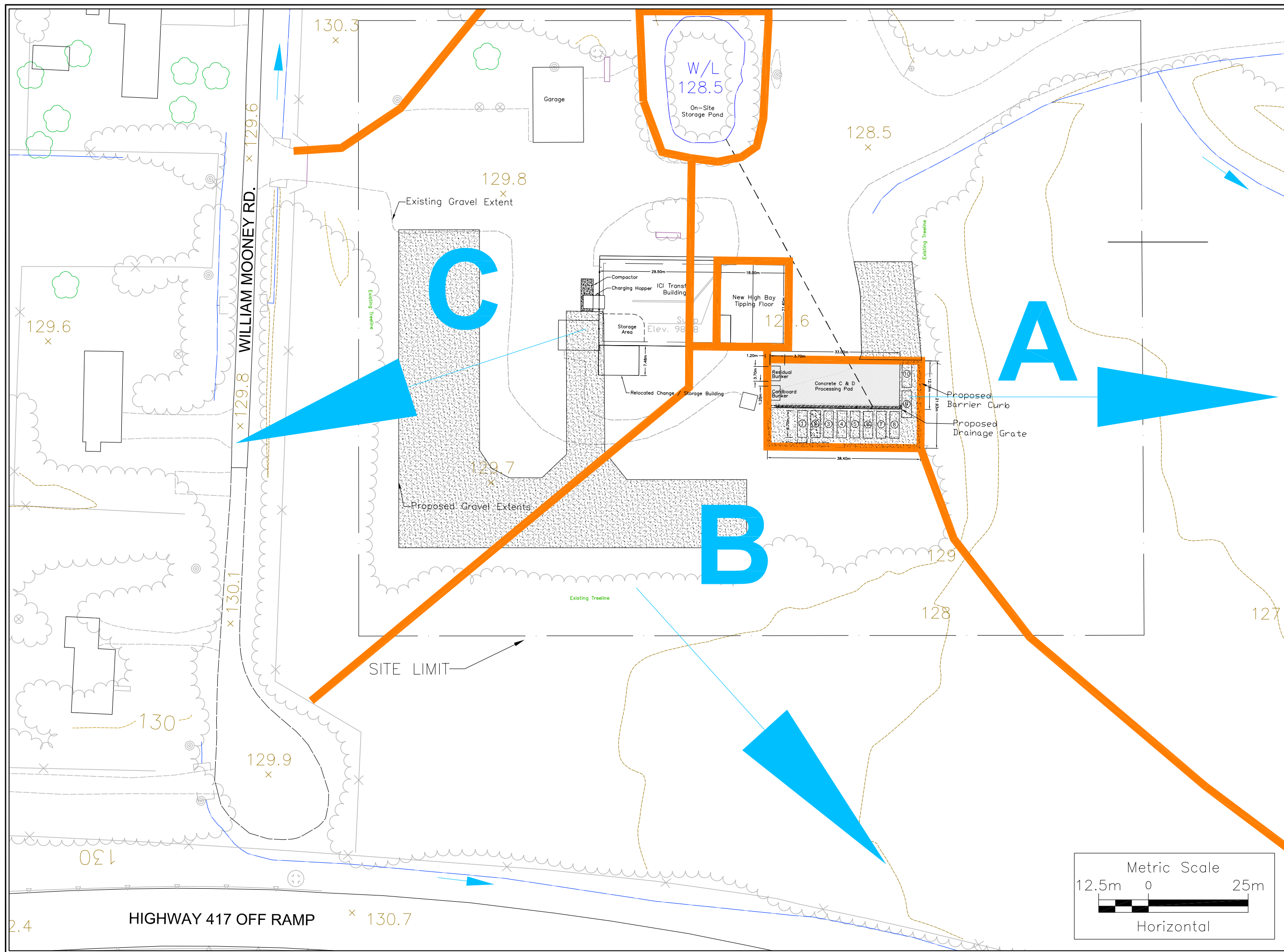
Major and minor drainage from the open-air C+D concrete sorting pad and adjacent gravel covered storage pad, will be collected by a trench drain and will be directed, by gravity flow in a sewer, directly to the existing on-site storage pond which will be periodically emptied by tanker truck and the contents disposed of in the landfill site leachate control pond. In a similar fashion, any runoff or wastewater on the new tipping floor, related to the ICI transfer building, will be absorbed either by residues from the ICI waste or a commercial absorbent; this will be trucked and disposed of in the landfill.

For those areas of the site that have been re-surfaced and modified from grass field to gravel, the increase in runoff has been determined using the Rational Method. Both minor (1:5 Year) and major (1:100 Year) flows were assessed based on City of Ottawa rainfall IDF curves and hydrologic parameters identified in **Table 1**, using composite MTO C values for various landuse and increased by 25% for the 1:100year event.

Flows have increased, generally by 10% as identified in **Table 1**, although flow from drainage area A has been reduced due to the ICI and C+D pads that will contain their own flow. The noted increases in flow are small, with the maximum 1:100 year flow being 290 l/s. Since all flows outlet as sheet flow to the surrounding wooded areas, and the distance of overland flows to a receiving water is between 50m to 100m, we have assumed that any erosion or flood impacts, as well as water quality impacts, would be mitigated by the overland flow route.

Table 1: Flow Estimates – Proposed Transfer Station											
Catchment ID (on-site)	A (ha)	S (%)	L (m)	C (MTO)		Tc (min)		Flow (m ³ /s)		% increase over existing	
				5yr	100yr	5yr	100yr	Q ₅	Q ₁₀₀	Q ₅	Q ₁₀₀
existing											
A	1.4	1.0	120	0.43	0.54	24	20	0.10	0.24		
B	0.6	1.0	80	0.39	0.49	21	18	0.05	0.11		
C	1.0	1.0	90	0.51	0.63	18	14	0.10	0.25		
proposed											
A	1.3	1.0	120	0.44	0.55	24	20	0.09	0.23	-10	-5
B	0.6	1.0	80	0.42	0.53	20	17	0.05	0.12	0	10
C	1.0	1.0	90	0.55	0.69	17	13	0.11	0.29	10	15

Based on the above analysis, it can be concluded that the proposed modifications to the site, to facilitate the new Transfer Station, would have negligible impact on local drainage.



No.	DATE	BY	ISSUES / REVISIONS
1			

LEGEND

- Gravity Pipe
- Proposed Concrete
- Proposed Gravel
- Drainage Flow Direction
- Drainage Divide



AECOM Canada Ltd.
 300 Water Street, Whitby, Ontario, Canada L1N 9J2
 T905.668.9363 F905.668.0221

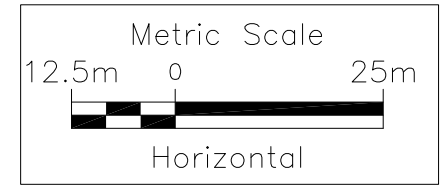
This drawing has been prepared for the use of AECOM's client and may not be used, reproduced or reflected in any other manner, without the prior written consent of AECOM. AECOM accepts no responsibility, and denies any liability whatsoever, to any party that modifies this drawing without AECOM's express written consent. Do not scale this document. All measurements must be obtained from stated dimensions.

CLIENT:
WASTE MANAGEMENT
 254 Westbrook Road, Ottawa, ON K0A 1L0

PROJECT:
OTTAWA WASTE TRANSFER & PROCESS FACILITY
 Waste Management of Canada Corporation
 William Mooney Rd, Ottawa

DRAWING:
GRADING, DRAINAGE, AND SITE SERVICES (OPTION 2)

DRAWN BY: CO	CHECKED BY: DP	PROJECT No.: 60191228
DESIGNED BY: PF	APPROVED BY:	DRAWING No. 1
SCALE: AS SHOWN	DATE: 16/02/2011	



TSHTE_TABLOID-VS.dwg - Dec 23 2002 - 9:33 AM

Appendix C

Summary of Vehicle Counts & Materials Diverted/Disposed

Appendix C1 - Inbound & Outbound Traffic Calculations (@ 20% Recovery Rate)

Inbound Waste Vehicle Count

400 Tonnes/Day

Vehicle Type	Vehicle Load Breakdown	Average Payload (tonnes)	Average Tonnes per Day by Vehicle Type	Average Number of Inbound Vehicles Per Day	Average Number of Inbound Vehicles Per hour (assume an average of 12 receiving hours per day)*
Inbound Transfer Station Vehicles					
Front End Loader (IC&I)	44%	9	110	12	1.0
Roll-Off (IC&I)	48%	5	120	24	2.0
Rear Loader (IC&I)	8%	6	20	3	0.3
TOTAL INBOUND IC&I VEHICLES				40	3.3
Inbound C&D Vehicles					
Roll-Off (C&D)	100%	2.5	150	60	5.0
TOTAL INBOUND C&D VEHICLES				60	5.0
TOTAL INBOUND IC&I & C&D VEHICLES INTO THE SITE				100	8

Note: * Numbers may not add up due to rounding

Summary of Waste Materials Diverted/Disposed

C & D Material Type (at 150 tonnes/day)	Composition	Assume 20% recovery rate of the targeted materials	Tonnes Diverted / Disposed Per Day	Tonnes Diverted / Disposed per Year (at 312 days/year)
Wood	26.00%	5.20%	7.8	2,434
Asphalt Paving	5.00%	1.00%	1.5	468
Asphalt Roofing	12.00%	2.40%	3.6	1,123
Scrap Metal	9.00%	1.80%	2.7	842
Concrete/Brick	12.00%	2.40%	3.6	1,123
OCC (assume 60% of the 14% paper composition is OCC)	8.40%	1.68%	2.5	786
Gypsum (Drywall)	10.00%	2.00%	3.0	936
Plastics (i.e., Plastic Pipe, Film, Mixed Plastics)	6.50%	1.30%	2.0	608
Residue	10.70%	83.22%	124.8	38,947
TOTAL*	100%	101.00%		
IC&I Material Type(at 250 tonnes/day)				
OCC	5%	1.00%	2.5	780
Scrap Metal	10%	2.00%	5.0	1,560
Residue	85%	97.00%	242.5	75,660
TOTAL	100%	100.00%		
TOTAL DIVERTED*			34	10,661
TOTAL DISPOSED*			367	114,607

Note: * Numbers may not add up due to rounding

Outbound Waste Vehicle Count

400 Tonnes/Day

Vehicle Type	Average Payload (tonnes)	Average Quantity of Material per day (tonnes)	Average Number of Outbound Vehicles per Day	Average Number of outbound Vehicles per hour (assume an average of 12 receiving hours per day)*
Residue Transfer Trailers (includes IC& & C&D Residue (post Sorting/Recovery)	30	367.33	12	1.0
IC&I Recovered OCC (Roll-Off Vehicles to market)	2.5	2.5	1	0.1
IC&I Recovered Scrap Metal (Roll-Off Vehicles to market)	5	5	1	0.1
TOTAL OUTBOUND VEHICLES FROM THE IC&I TRANSFER STATION			14	1.2
Roll-Off Vehicles (to secondary processors/markets)				
1. Wood	5	7.80	2	0.1
2. Asphalt Paving	5	1.50	0	0.0
3. Asphalt Roofing	5	3.60	1	0.1
4. Scrap Metal	5	2.70	1	0.0
5. Concrete/Brick	5	3.60	1	0.1
6. OCC (assume 60% of the 14% paper composition is OCC)	2.5	2.52	1	0.1
7. Gypsum (Drywall)	5	3.00	1	0.1
8. Plastics (Plastic Pipe/Film/Mixed Plastics)	2.5	1.95	1	0.1
TOTAL OUTBOUND VEHICLES (ROLL-OFFS) FROM THE C&D MATERIALS SORTING/RECOVERY OPERATIONS			6	0.5
TOTAL OUTBOUND VEHICLES FROM THE SITE			20	2

Note: * Numbers may not add up due to rounding

Summary of In/Outbound Vehicle Counts

VEHICLE TYPE	Per Hour	Per day
RESIDUE TRANSFER TRAILERS	1	12
VEHICLES ASSOCIATED WITH THE IC&I TRANSFER STATION TIP FLOOR	3	42
VEHICLES ASSOCIATED WITH THE C&D PAD	6	66
TOTAL VEHICLE COUNTS*	10	120

TOTAL WASTE MATERIALS/RESIDUE FROM FROM IC&I & C&D OPERATIONS
40 IN/ 6 OUTBOUND
60 IN/19 OUTBOUND
100 INBOUND PLUS 35 OUTBOUND

Note: * Numbers may not add up due to rounding

Appendix C2 - Inbound & Outbound Traffic Calculations (@ 60% Recovery Rate)

Inbound Waste Vehicle Count

400

Tonnes/Day

Vehicle Type	Vehicle Load Breakdown	Average Payload (tonnes)	Average Tonnes per Day by Vehicle Type	Average Number of Inbound Vehicles Per Day	Average Number of Inbound Vehicles Per hour (assume an average of 12 receiving hours per day)*
Inbound Transfer Station Vehicles					
Front End Loader (IC&I)	44%	9	110	12	1.0
Roll-Off (IC&I)	48%	5	120	24	2.0
Rear Loader (IC&I)	8%	6	20	3	0.3
TOTAL INBOUND IC&I VEHICLES				40	3.3
Inbound C&D Vehicles					
Roll-Off (C&D)	100%	2.5	150	60	5.0
TOTAL INBOUND C&D VEHICLES				60	5.0
TOTAL INBOUND IC&I & C&D VEHICLES INTO THE SITE				100	8

Note: * Numbers may not add up due to rounding

Summary of Waste Materials Diverted/Disposed

C & D Material Type (at 150 tonnes/day)	Composition	Assume 60% recovery rate of the targeted materials	Tonnes Diverted/Disposed Per Day	Tonnes Diverted/Disposed per Year (at 312 days/year)
Wood	26.00%	15.60%	23.4	7,301
Asphalt Paving	5.00%	3.00%	4.5	1,404
Asphalt Roofing	12.00%	7.20%	10.8	3,370
Scrap Metal	9.00%	5.40%	8.1	2,527
Concrete/Brick	12.00%	7.20%	10.8	3,370
OCC (assume 60% of the 14% paper composition is OCC)	8.40%	5.04%	7.6	2,359
Gypsum (Drywall)	10.00%	6.00%	9.0	2,808
Plastics (i.e., Plastic Pipe, Film, Mixed Plastics)	6.50%	3.90%	5.9	1,825
Residue	10.70%	47.66%	71.5	22,305
TOTAL*	100%	101.00%		
IC&I Material Type(at 250 tonnes/day)				
OCC	5%	3.00%	7.5	2,340
Scrap Metal	10%	6.00%	15.0	4,680
Residue	85%	91.00%	227.5	70,980
TOTAL	100%	100.00%		
TOTAL DIVERTED*			103	31,983
TOTAL DISPOSED*			299	93,285

Note: * Numbers may not add up due to rounding

Outbound Waste Vehicle Count

400

Tonnes/Day

Vehicle Type	Average Payload (tonnes)	Average Quantity of Material per day (tonnes)	Average Number of Outbound Vehicles per Day	Average Number of outbound Vehicles per hour (assume an average of 12 receiving hours per day)*
Residue Transfer Trailers (includes IC& & C&D Residue (post Sorting/Recovery)	30	298.99	10	0.8
IC&I Recovered OCC (Roll-Off Vehicles to market)	2.5	7.5	3	0.3
IC&I Recovered Scrap Metal (Roll-Off Vehicles to market)	5	15	3	0.3
TOTAL OUTBOUND VEHICLES FROM THE IC&I TRANSFER STATION			16	1.3
Roll-Off Vehicles (to secondary processors/markets)				
1. Wood	5	23.40	5	0.4
2. Asphalt Paving	5	4.50	1	0.1
3. Asphalt Roofing	5	10.80	2	0.2
4. Scrap Metal	5	8.10	2	0.1
5. Concrete/Brick	5	10.80	2	0.2
6. OCC (assume 60% of the 14% paper composition is OCC)	2.5	7.56	3	0.3
7. Gypsum (Drywall)	5	9.00	2	0.2
8. Plastics (Plastic Pipe/Film/Mixed Plastics)	2.5	5.85	2	0.2
TOTAL OUTBOUND VEHICLES (ROLL-OFFS) FROM THE C&D MATERIALS SORTING/RECOVERY OPERATIONS			19	1.6
TOTAL OUTBOUND VEHICLES FROM THE SITE			35	3

Note: * Numbers may not add up due to rounding

Summary of In/Outbound Vehicle Counts

VEHICLE TYPE	Per Hour	Per day
RESIDUE TRANSFER TRAILERS	1	10
VEHICLES ASSOCIATED WITH THE IC&I TRANSFER STATION TIP FLOOR	4	46
VEHICLES ASSOCIATED WITH THE C&D PAD	7	79
TOTAL VEHICLE COUNTS*	11	134

TOTAL WASTE MATERIALS/RESIDUE FROM FROM IC&I & C&D OPERATIONS
40 IN/ 6 OUTBOUND
60 IN/19 OUTBOUND
100 INBOUND PLUS 35 OUTBOUND

Note: * Numbers may not add up due to rounding

Appendix D

Calculations of On-Site Storage

Appendix D Calculations of Storage Capacity

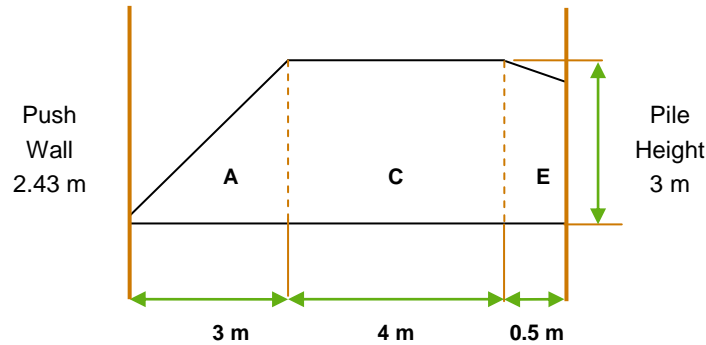
1. Waste Storage Capacity for Transfer Station

Calculation Assumptions

Maximum Individual Storage Area:.....	1,000 m ²	(as per fire code)
Total Waste Unloading and Storage Area (SW Corner):	182 m ²	
Total Waste Unloading and Storage Area (NW Corner):	33 m ²	
Total Storage Capacity of Recovered Scrap Metal:.....	1 bin x 5 tonnes = 5 tonnes	
Total Storage Capacity of Recovered OCC:.....	1 bin x 5 tonnes = 5 tonnes	
Clearance from Building Walls:	0 m on each site. Walls reinforced	
Height of Push Wall:.....	2.43 m (8 feet)	
Maximum Pile Height (SW Corner):	3 m	
Average Pile Height (NW Corner):	2 m	
Pile Side Slopes:	1:1	
Waste Density:.....	240 kg/m ³	

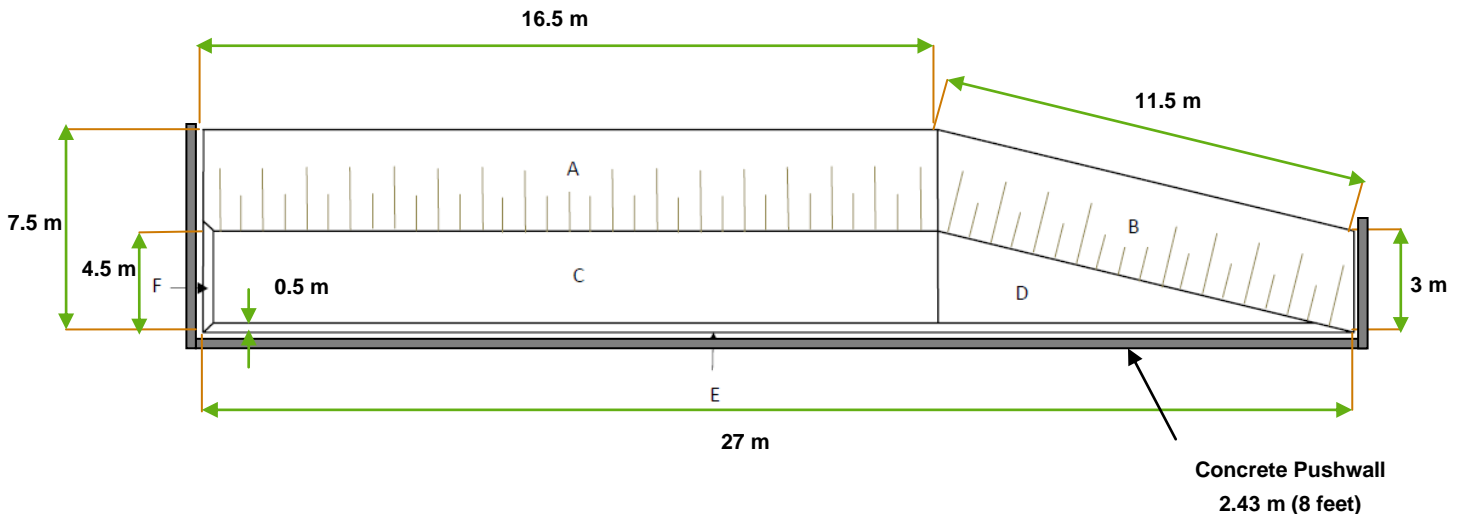
Cross Section of the SW Waste Pile

Not to scale



Overhead View of the SW Corner Waste Pile

Not to scale



Volume Calculations of SW Waste Pile on the Tip Floor

$$\begin{aligned} \text{Part A:} & \dots\dots\dots = (3 \text{ m} \times 3 \text{ m} \times 16.5 \text{ m}) \times \frac{1}{2} \\ & \dots\dots\dots = \mathbf{74 \text{ m}^3} \end{aligned}$$

$$\begin{aligned} \text{Part B:} & \dots\dots\dots = (3 \text{ m} \times 3 \text{ m} \times 11.5 \text{ m}) \times \frac{1}{2} \\ & \dots\dots\dots = \mathbf{52 \text{ m}^3} \end{aligned}$$

$$\begin{aligned} \text{Part C:} & \dots\dots\dots = (4 \text{ m} \times 3 \text{ m} \times 16 \text{ m}) \\ & \dots\dots\dots = \mathbf{192 \text{ m}^3} \end{aligned}$$

$$\begin{aligned} \text{Part D:} & \dots\dots\dots = ((4 \text{ m} \times 11.5 \text{ m} \times \frac{1}{2}) \times 3 \text{ m}) \\ & \dots\dots\dots = \mathbf{69 \text{ m}^3} \end{aligned}$$

$$\begin{aligned} \text{Part E:} & \dots\dots\dots = (3 \text{ m} \times 0.5 \text{ m} \times 27 \text{ m}) - ((0.5 \text{ m} \times 0.5 \text{ m} \times 27 \text{ m}) \times \frac{1}{2}) \\ & \dots\dots\dots = (40.5 \text{ m}^3) - (3.375 \text{ m}^3) \\ & \dots\dots\dots = \mathbf{37 \text{ m}^3} \end{aligned}$$

$$\begin{aligned} \text{Part F:} & \dots\dots\dots = (3 \text{ m} \times 0.5 \text{ m} \times 4.5 \text{ m}) - ((0.5 \text{ m} \times 0.5 \text{ m} \times 4.5 \text{ m}) \times \frac{1}{2}) \\ & \dots\dots\dots = (6.75 \text{ m}^3) - (0.5 \text{ m}^3) \\ & \dots\dots\dots = \mathbf{6 \text{ m}^3} \end{aligned}$$

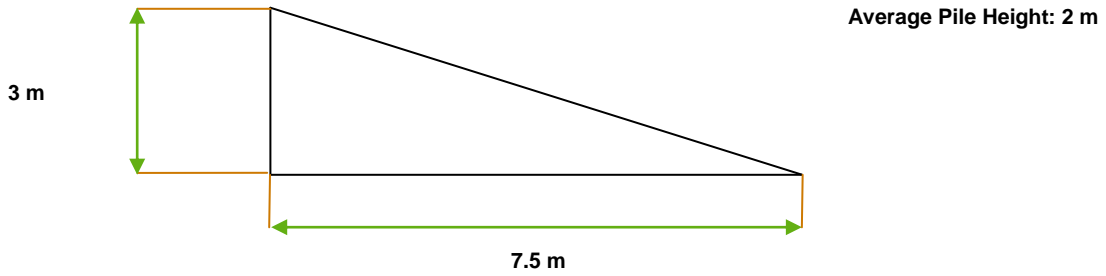
$$\begin{aligned} \text{Maximum Waste Volume:} & \dots\dots\dots = A + B + C + D + E + F \\ & \dots\dots\dots = 74 + 52 + 192 + 69 + 37 + 6 \\ & \dots\dots\dots = \mathbf{430 \text{ m}^3} \end{aligned}$$

$$\text{Waste Density:} \dots\dots\dots = \mathbf{240 \text{ kg/m}^3}$$

$$\begin{aligned} \text{Total Waste Storage Capacity at the SW} & \dots\dots\dots = \text{Maximum Waste Storage Volume} \times \text{Waste Density} \\ \text{Corner of the Tip Floor :} & \dots\dots\dots \\ & \dots\dots\dots = 430 \text{ m}^3 \times 240 \text{ kg/m}^3 \\ & \dots\dots\dots = \mathbf{103,200 \text{ kg} = 103 \text{ tonnes}} \end{aligned}$$

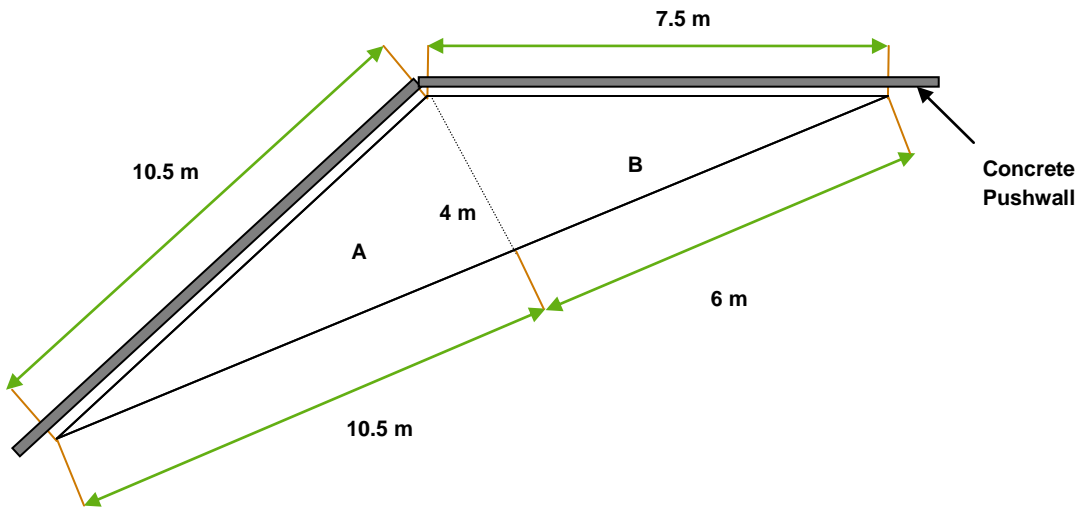
Cross Section View of the NW Corner Waste Pile

Not to scale



Overhead View of the NW Corner Waste Pile

Not to scale



Volume Calculations of NW Waste Pile on Tipping Floor

Part A:..... = (4 m x 10.5 m x ½) x 2 m)
 = 42 m³

Part B:..... = (4 m x 6 m x ½ m) x 2 m)
 = 24 m³

Maximum Waste Volume: = A + B
 = 42 + 24
 = 66 m³

Waste Density:..... = 240 kg/m³

Total Waste Storage Capacity at the NW
 Corner of the Tip Floor: = Maximum Waste Storage Volume x Waste Density
 = 66 m³ x 240 kg/m³
 = 15,840 kg = 15.8 tonnes = 16 tonnes

Total Waste Storage Capacity at the Transfer Station

Waste Storage Capacity (SW Corner Waste Pile): = 103 tonnes

Waste Storage Capacity (NW Corner Waste Pile): = 16 tonnes

Total Waste Storage Capacity at the Transfer Station: = 119 tonnes

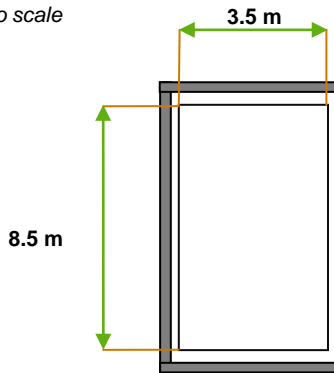
2. C&D Storage Capacity

Calculation Assumptions

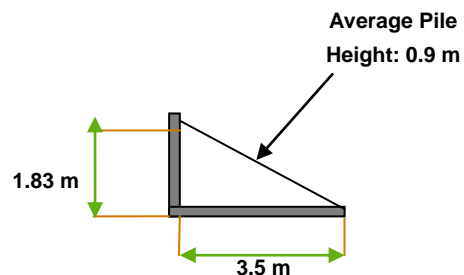
- Maximum Individual Storage Area:..... 1,000 m² (as per fire code)
- Total Storage Area C&D Residual:..... 30 m² (3.5 m x 8.5 m)
- Height of C&D Residual Bunker Push Wall:..... 1.83 m (6 feet)
- Average Residual Pile Height:..... 0.5 m
- Pile Side Slopes: 1:1
- Waste Density:..... 240 kg/m³

C&D Residual Waste Pile

Not to scale



Overhead View of Waste Pile



Section View of Waste Pile

Volume Calculations of C&D Residual Bunker

Waste Pile: = 8.5 m x 3.5 m x 0.9 m
 = **26.7 m³**

Waste Density:..... = **240 kg/m³**

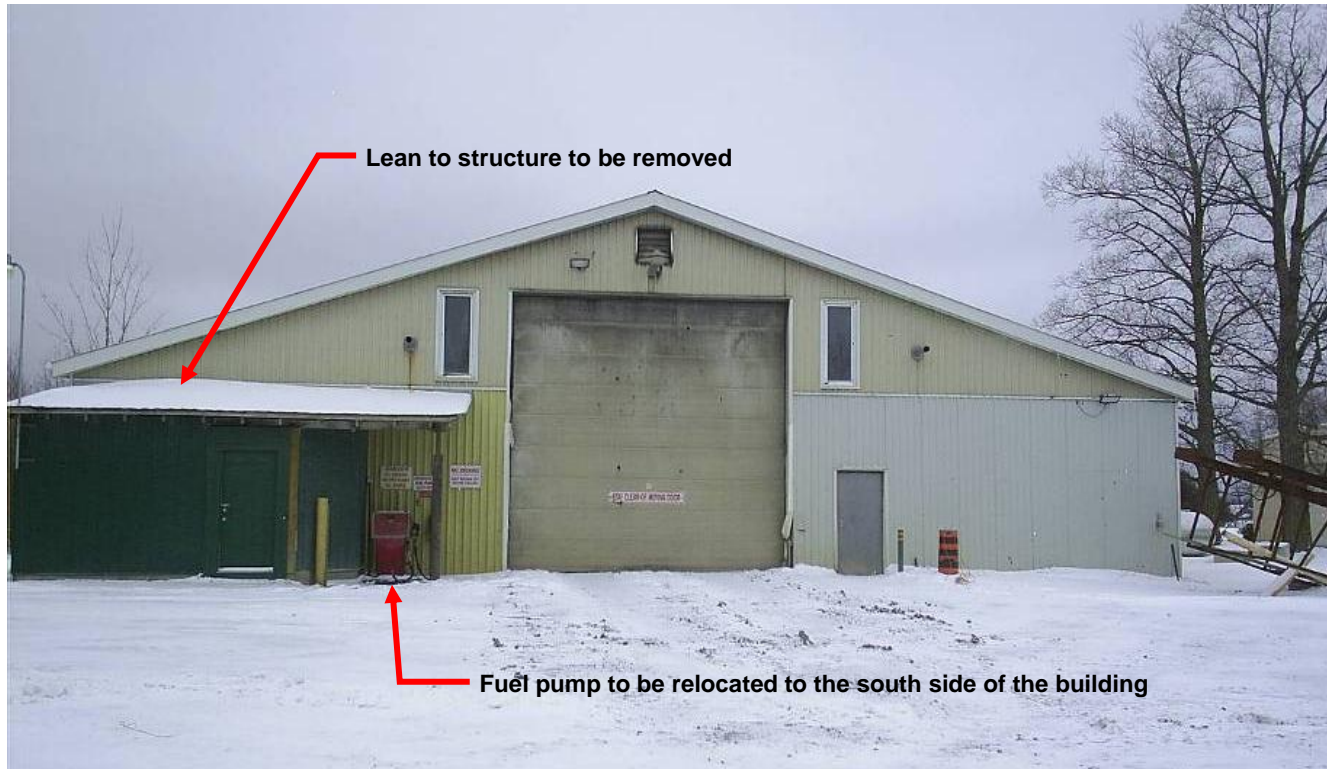
Total Waste Storage Capacity on the C&D Processing Pad:..... = Maximum Waste Storage Volume x Waste Density
 = 15 m³ x 240 kg/m³
 = **6,426 kg = 6.4 tonnes**

Appendix E

Site/Building Photographs

Appendix E. Site/Building Photographs

East Elevation of Former Maintenance Shop



Southeast Corner of Maintenance Shop



South Elevation of Maintenance Shop



West Elevation of Maintenance Shop



North Elevation of Maintenance Shop

